

# C-SERIES

## C4,000 - Diesel

The multi-directional forklift designed for the safe, space saving and productive handling of long and bulky loads.

# COMBILIFT

LIFTING INNOVATION



rev. 1.8

[combilift.com](http://combilift.com)

# C-SERIES

## C4,000 - Diesel

FRONTAL  
MODE

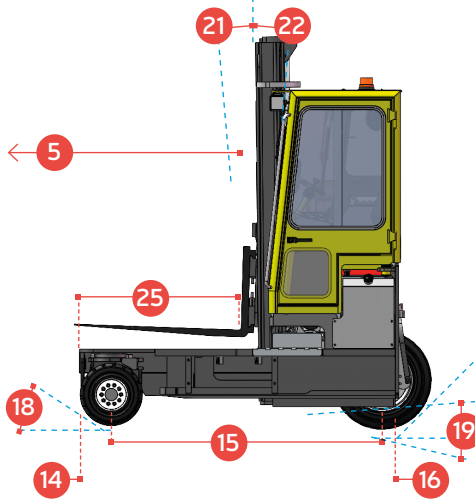

SiDEWARD  
MODE

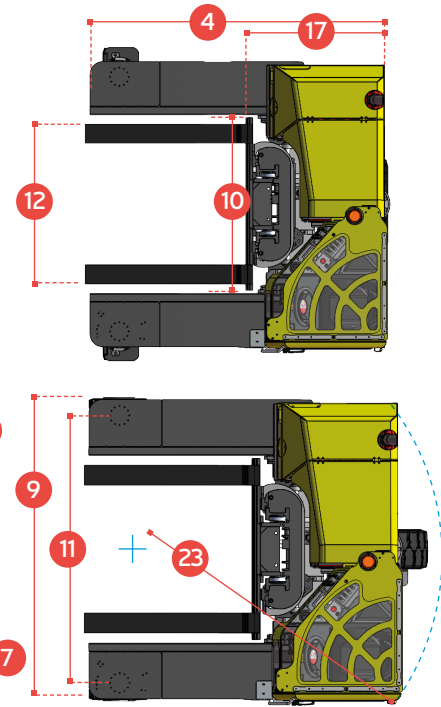
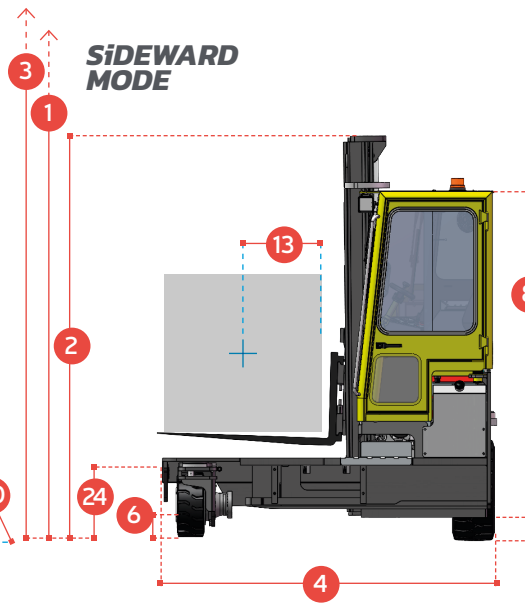

REF.	DESCRIPTION	C4000
1a	Standard Lift Height	4040 mm
1b	Free Lift Height	0 mm
2	Height Mast Closed	2855 mm
3	Max. (Mast Raised)	4870 mm
4	Overall Length	2300 mm
5	Mast Travel	1300 mm
6	Ground Clearance Under Mast	150 mm
7	Ground Clearance to Wheelbase Centre	200 mm
8	Height Over Cab or of Overhead Guard	2435 mm
9	Width	2230 mm
10	Outside Spread of Fork Arms	1350 mm
11	Track Front	1990 mm
12	Frame Opening	1400 mm
13	Load Centre Distance	600 mm
14	Overhang Front	235 mm
15	Wheel Base	1915 mm
16	Overhang Back	115 mm
17	Length from Face of Fork	1100 mm
18	Approach Angle	45°
19	Ramp Angle	29°
20	Departure Angle	45°
21	Forward Tilt	3°
22	Backward Tilt	5°
23	Minimum Outside Radius	2325 mm
24	Platform Height	545 mm
25	Platform Length	1200 mm
A	Capacity	4000 kg
B	Unladen Weight	6300 kg
C	Maximum Ground Speed	15 km/h
D	Gradeability	15%
E	Kubota 03 Series diesel engine	48.6 kW
F	Electrics	12 Volt
G	Fork Sections 50mm x 150mm	1200 mm
H	200 / 50 x 10 Super Elastic Front Tyre	OD450 mm / Width 200 mm
I	28 x 12.5 - 15 Super Elastic Rear Tyre	OD 720 mm / Width 295 mm
J	Standard Colour	Green and Grey
K	Suspension Seat	KAB Model 116

### Multi-Directional

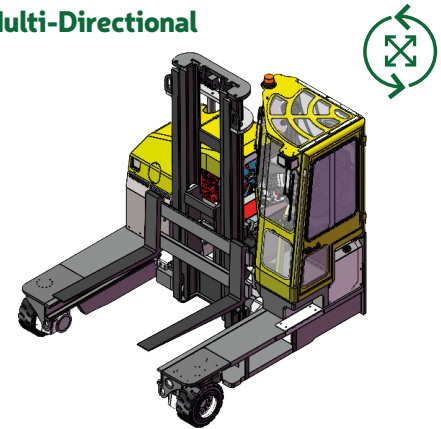

### Features Include:

- Rubber Mounted Cabin
- Multi-Directional Operation
- 3 Wheel Hydrostatic Drive
- Load Sensing Steering
- 4 Way Lever Positioning of Wheels
- Hydraulic Oil Cooler
- Wheel Position Display

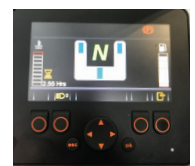

### Distributed by:

European Patent No. 2167416; Brazilian Patent No. P10811954-6;  
Australian Patent No. 2008253242 UK Patent No. 1803601.2

COMBILIFT HAS A POLICY OF CONTINUOUS PRODUCT DEVELOPMENT AND RESERVES THE RIGHT TO ALTER SPECIFICATIONS WITHOUT PRIOR NOTICE. SPECIFICATIONS AND/OR DIMENSIONS MAY VARY FROM THOSE ILLUSTRATED IN SOME COUNTRIES.

CO. MONAGHAN +353 47 80500  
IRELAND INFO@COMBILIFT.COM

combilift.com